

## Class150-600 Two-Piece Floating Ball Valve

Gate Valve, Globe Valve, Plug Valve, Check Valve, Butterfly Valve ,  
 Power Station Valve ,Oilfield Dedicated Valve Y-Strainer.

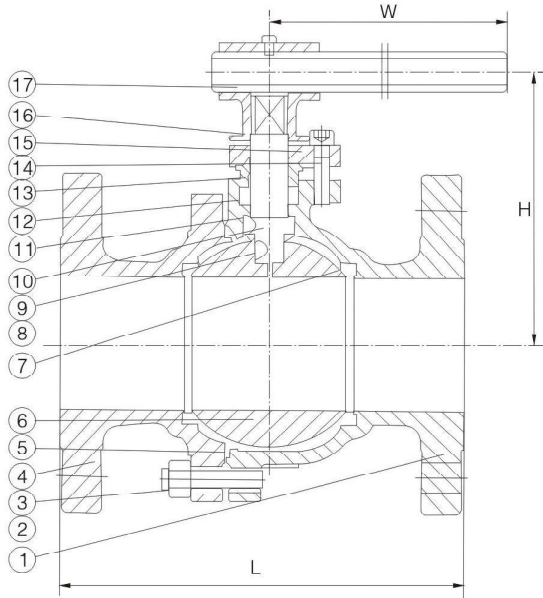

**STANDARDS**  
 Design and manufacture: API6D API608 or BS 5351  
 Face to Face Dimensions: ANSI B16.10  
 End Flange Dimensions: ANSI B16.5  
 Test: API 6D or API 598

**Type of Connection**  
 RF and RTJ Flange Ends to ANSI B16.5 standard.  
 BW Flange Ends to ANSI B16.25 standard.

**Type of Operation**  
 Lever  
 Connection of Worm Gear actuator, Electric actuator,  
 Pneumatic actuator to ISO 5211 standard.  
 Anti-static electricity constructions "AS" and Fire-safe  
 constructions "FD"

### Standard Material Specifications

No	Part Name	Carbon steel to ASTM			Stainless Steel to ASTM		
		WCB	LCB	CF8	CF8M	CF3	CF3M
1	Body	A216 WCB	A352 LCB	A351 CF8	A351 CF8M	A351 CF3	A351 CF3M
2	Bonnet nut	A194 2H	A194 4	A194 8			
3	Bonnet bolt	A193 B7	A320 1 7	A193 B8			
4	Cap	A216 WCB	A352 LCB	A351 CF8	A351 CF8M	A351 CF3	A351 CF3M
5	Gasket	SS Spiral Wound/graphite or SS Spiral Wound/PTFF					
6	Ball	A105/Ep.Cr or F6	A182 F6	A351 CF8	A351 CF8M	A351 CF3	A351 CF3M
7	Seat Ring	RPTFE or POM					
8	Small spring	Stainless Steel					
9	Small ball	A182 F304 A182 F316L					
10	Stem	A182 F6	A182 F6	A182 F304	A182 F316	A182 F304L	A182 F316L
11	Stem Seat	PIFF					
12	Stem Packing	PTFE or Graphite					
13	Gland	A182 F6		A182 F304	A182 F316	A182 F304L	A182 F316L
14	Gland Bolt	A193 B7		A193 B8			
15	Gland Flange	A216 WCB		A351 CF8			
16	Positioning Plate	Steel					
17	Wrench	A216 WCB					

The material is according to ASTM standard.



## Class150-600 Two-Piece Floating Ball Valve

Gate Valve, Globe Valve, Plug Valve, Check Valve, Butterfly Valve ,  
 Power Station Valve ,Oilfield Dedicated Valve Y-Strainer.

### Dimensions and Weights

CLASS 150												
DN	mm	15	20	25	40	50	65	80	100	150	200	250
NPS	in	1/2	3/4	1	1 1/2	2	2 1/2	3	4	6	8	10
L(RF)	mm	108	117	127	165	178	191	203	229	394	457	533
	in	4.25	4.6	5	6.5	7	7.5	8	9	15.5	18	21
L1(BW)	mm	140	152	165	190	216	241	283	305	457	521	559
	in	5.5	6	6.5	7.48	8.5	9.5	11.13	12	18	20.5	22
L2(RTJ)	mm	119	129.7	139.7	178	191	203	216	241	406	470	546
	in	4.69	5.11	5.5	6.9	7.5	8	8.5	9.5	16	18.5	21.5
H	mm	66	74	87	105	132	152	182	215	250	285	495
	in	2.6	2.9	3.48	4.2	5.28	6.08	7.28	8.6	10	11.4	19.5
Do(W)	mm	130	130	160	230	400	400	600	850	1100	1500	*350
	in	5.1	5.1	6.3	9	15.74	15.74	23.62	33.46	43.3	59	13.8
RF(Kg)		2.3	3	4.5	7	15	20	25	40	97	160	240
BW(Kg)		2.0	2.5	3.8	5.8	12	17	21	36	92.8	154	227

CLASS 300												
DN	mm	15	20	25	40	50	65	80	100	150	200	
NPS	in	1/2	3/4	1	1 1/2	2	2 1/2	3	4	6	8	
L(RF)	mm	140	152	165	190	216	241	283	305	403	502	
	in	5.5	5.98	6.5	7.48	8.5	8.5	11.13	12	15.88	19.75	
L1(BW)	mm	140	152	165	190	216	241	283	305	457	521	
	in	5.5	5.98	6.5	7.48	8.5	9.5	11.13	12	18	20.5	
L2(RTJ)	mm	151	164.7	177.7	202.7	232	257	298	321	419	518	
	in	5.95	6.48	7	8	9.13	10.13	11.75	12.63	16.5	20.38	
H	mm	66	74	87	105	115	158	166	183	285	294	
	in	2.6	2.9	3.48	4.2	4.6	6.32	6.64	7.32	11.4	11.76	
Do(W)	mm	130	130	160	230	400	400	600	850	1100	1500	
	in	5.1	5.1	6.3	9	15.74	15.74	23.62	33.46	43.3	59	
RF(Kg)		2.5	3.5	5.5	10.5	20	25	31	52	118	200	
BW(Kg)		2.1	3	4.8	8.7	17	22	28	48	105	185	

CLASS 600									
DN	mm	15	20	25	40	50	65	80	
NPS	in	1/2	3/4	1	1 1/2	2	2 1/2	3	
I (RF)	mm	165	190	216	241	292	330	356	
	in	6.5	7.48	8.5	9.5	11.5	13	14	
L1(BW)	mm	165	190	216	241	292	330	356	
	in	6.5	7.48	8.5	9.5	11.5	13	14	
L2(RTJ)	mm	163.4	190	216	241	295	333	359	
	in	6.43	7.48	8.5	9.5	11.63	13.13	14.13	
H	mm	59	63	75	107	153	165	195	
	in	2.3	2.5	2.95	4.2	6.02	6.5	7.68	
Do(W)	mm	130	160	160	230	600	850	1250	
	in	5.1	6.3	6.3	9	23.62	33.46	49.25	
RF(Kg)		7.5	10.5	14.5	18.5	38	56	66	
BW(Kg)		6	8.7	11	14.7	31	49	58	

\* Worm Gear of Electric actuator operated.

## Class150-1500 Two-PieceTrunnion Mounted Ball Valve

Gate Valve, Globe Valve, Plug Valve, Check Valve, Butterfly Valve ,  
 Power Station Valve ,Oilfield Dedicated Valve Y-Strainer.

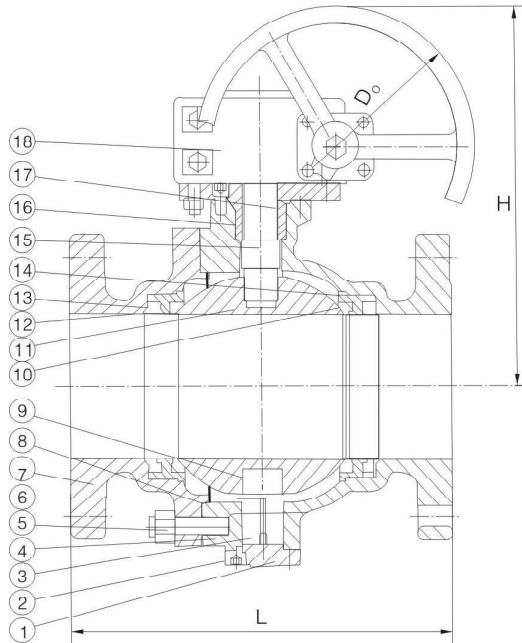

### STANDARDS

Design and manufacture: API6D, API608, ANSI B16.34  
 or BS 5351

Face to face dimensions: ANSI B16.10

Pressure-Temp Ratings: ANSI B16.34

Test: API 6D or API 598

End flange dimensions

NPS 2-24: ANSI B16.5

NPS 26: ANSI B16.47 or MSS SP-44

### Standard Material Specifications

No	Part Name	Carbon steel to ASTM			Stainless Steel to ASTM		
		WCB	LCB	CF8	CF8M	CF3	CF3M
1	Underplate	WCB	LCB	CF8	CF8M	CF3	CF3M
2	Underplate Bolt	A193 B7	A320 L7	A193 B8			
3	Trunnion	A182 F6	A182 F6	A182 F304	A182 F316	A182 F304L	A182 F316L
4	Body	A216 WCB	A352 LCB	A351 CF8	A351 CF8M	A351 CF3	A351 CF3M
5	Bonnet Nut	A194 2H	A194 4	A194 8			
6	Bonnet Bolt	A193 B7	A320 L7	A193 B8			
7	Cap	A216 WCB	A352 LCB	A351 Cf8	A351 CF38M	A351 CF3	A351 CF3M
8	Gasket	SS Spiral Wound/graphite or SS Spiral Wound/PTFE					
9	Shaft Sleeve	SS/graphite					
10	Seat Ring	RPTFE or POM					
11	Ball	A105/Ep.Cr or F6	A182 F6	A351 CF8	A351 CF8M	A351 CF3	A351 CF3M
12	Seat	A105/Ep.Cr or F6	A182 F6	A182 F304	A182 F316	A182 F304L	A182 F316L
13	Spring	17-17PH(inconel for NACE) Ni-cr Alloy					
14	O-Ring	Viton					
15	Stem	A182 F6	A182 F6	A182 F304	A182 F316	A182 F304L	A182 F316L
16	Sealing Cover	A182 F6	A182 F6	A182 F304	A182 F316	A182 F304L	A182 F316L
17	O-Ring	Viton					
18	Gear Actuator						

The material is according to ASTM standard.

## Class150-1500 Three-Piece Trunnion Mounted Ball Valve

Gate Valve, Globe Valve, Plug Valve, Check Valve, Butterfly Valve ,  
 Power Station Valve ,Oilfield Dedicated Valve Y-Strainer.

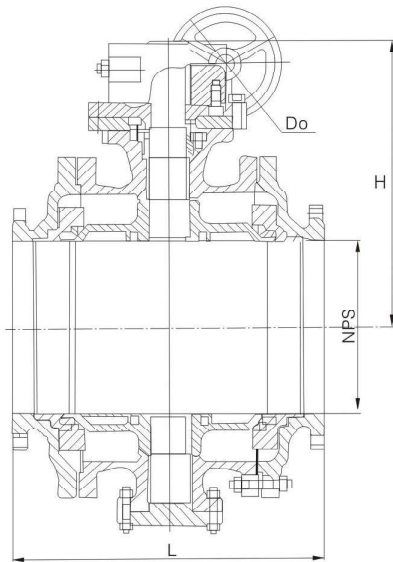

Type of connection  
 R F and RTJ flange ends to ANSI B16.5 or ANSI B16.47  
 and MSS SP-44 standard.  
 BW flange ends to ANSI B16.25 standard.

Type of operation  
 Lever  
 Connection dimensions of Worm Gear actuator.  
 Electric actuator, Pneumatic actuator to ISO 5211 standard.  
 Anti-static Electricity constructions "AS" and  
 Fire-safe constructions "FD".

### Dimensions and Weights

CLASS 150															
DN	mm	50	65	80	100	150	200	250	300	350	400	450	500	600	700
NPS	in	2	2 1/2	3	4	6	8	10	12	14	16	18	20	24	28
L(RF)	mm	178	191	203	229	394	457	533	610	686	762	864	914	1067	1245
	in	7	7.5	8	9	15.5	18	21	24	27	30	34	36	42	49
L1(BW)	mm	216	241	283	305	457	521	559	635	762	838	914	991	1143	1346
	in	8.5	9.5	11.13	12	18	20.5	22	25	30	33	36	39	45.5	53
L2(RTJ)	mm	191	203	216	241	406	470	546	622	699	775	876	927	1080	
	in	7.5	8	8.5	9.5	16	18.5	21.5	24.5	27.5	30.5	34.5	36.5	42.5	
H	mm	153	165	195	213	272	342	495	580	625	720	790	840	1050	1150
	in	6.05	6.5	7.68	8.39	10.7	13.5	19.5	22.85	24.6	28.35	31	33.1	41.34	45.3
Do(W)	mm	400	400	600	850	1100	1500	*350	*350	*600	*600	*800	*800	*800	*800
	in	15.74	15.74	23.62	33.46	43.3	59	13.8	13.8	23.6	23.6	31.5	31.5	31.5	31.5
RF(Kg)		15	19	38	65	97	160	240	390	510	750	895	1190	2100	3000
BW(Kg)		13	17	35	55	92.8	154	227	365	478	711	868	1138	2015	2900

CLASS 300															
DN	mm	50	65	80	100	150	200	250	300	350	400	450	500	600	700
NPS	in	2	2 1/2	3	4	6	8	10	12	14	16	18	20	24	28
L(RF)	mm	216	241	283	305	403	502	568	648	762	838	914	991	1143	1346
	in	8.5	9.5	11.13	12	15.88	19.75	22.38	25.5	30	33	36	39	45	53
L1(BW)	mm	216	241	283	305	457	521	559	635	762	838	914	991	1143	1346
	in	8.5	9.5	11.13	12	18	20.5	22	25	30	33	36	39	45	53
L2(RTJ)	mm	232	257	298	321	419	518	584	664	778	854	930	1010	1165	1372
	in	9.13	10.13	11.75	12.63	16.5	20.38	23	26.13	30.63	33.63	36.63	39.75	45.89	54
H	mm	153	165	195	213	272	342	495	580	625	720	790	840	1050	1150
	in	6.02	6.5	7.68	8.39	10.7	13.5	19.5	22.85	24.6	28.35	31	33.1	41.34	45.3
Do(W)	mm	400	400	600	850	1100	1500	*350	*350	*600	*600	*800	*800	*800	*800
	in	15.74	15.74	23.62	33.46	43.3	59	13.8	13.8	23.6	23.6	31.5	31.5	31.5	31.5
RF(Kg)		18	27	47	80	118	200	365	530	740	1030	1320	1540	2600	3900
BW(Kg)		14	22	38	65	105	185	342	503	713	1000	1285	1498	2540	3825

\* Worm Gear or Electric actuator operated.





## Trunnion Mounted Ball Valve

Gate Valve, Globe Valve, Plug Valve, Check Valve, Butterfly Valve ,  
 Power Station Valve , Oilfield Dedicated Valve Y-Strainer.

### Dimensions and Weights

CLASS 600													
DN	mm	50	65	80	100	150	200	250	300	350	400	450	500
NPS	in	2	2 1/2	3	4	6	8	10	12	14	16	18	20
L(RF)	mm	292	330	356	432	559	660	787	838	889	991	1092	1194
	in	11.5	13	14	17	22	26	31	33	35	39	43	47
L1(BW)	mm	292	330	356	432	559	660	787	838	889	991	1092	1194
	in	11.5	13	14	17	22	26	31	33	35	39	43	47
L2(RTJ)	mm	295	333	359	435	562	664	791	841	892	994	1095	1200
	in	11.63	13.13	14.13	17.13	22.13	26.13	31.13	33.13	35	39.5	43.1	47.3
H	mm	153	165	195	213	272	342	495	580	630	725	800	850
	in	6.02	6.5	7.68	8.39	10.7	13.5	19.5	22.85	24.8	28.5	31.5	33.5
Do(W)	mm	600	850	1250	1300	1500	*350	*350	*600	*600	*800	*800	*800
	in	23.62	33.46	49.25	51.22	59	13.8	13.8	23.6	23.6	31.5	31.5	31.5
RF(Kg)		38	56	66	122	217	350	660	820	830	1160	1420	1650
BW(Kg)		31	51	58	117	200	327	605	790	800	1030	1305	1505

CLASS 900													
DN	mm	50	65	80	100	150	200	250	300	350	400	450	500
NPS	in	2	2 1/2	3	4	6	8	10	12	14	16	18	20
L(RF)	mm	368	419	381	457	610	737	838	965	1029	1130	1219	1321
	in	14.5	16.5	15	18	24	29	33	38	40.5	44.5	48	52
L1(BW)	mm	368	419	381	457	610	737	838	965	1029	1130	1219	1321
	in	14.5	16.5	15	18	24	29	33	38	40.5	44.5	48	52
L2(RTJ)	mm	371	422	384	460	613	740	841	968	1032	1133	1222	1327
	in	14.63	16.63	15.13	18.13	24.13	29.13	33.13	38.13	40.6	44.6	48.1	52.3
H	mm	162	195	205	239	290	355	510	595	650	750	835	900
	in	6.36	7.7	80.5	9.41	11.4	14	20	23.4	25.6	29.5	32.9	35.4
Do(W)	mm	600	850	1250	1300	1500	*350	*350	*600	*600	*800	*800	*800
	in	23.62	33.46	49.25	51.22	59	13.8	13.8	23.6	23.6	31.5	31.5	31.5
RF(Kg)		48	60	78	138	315	480	710	890	910	1200	1480	1760
BW(Kg)		44.5	52.5	75.2	131	297	440	690	827	870	1100	1210	1620

CLASS 1500													
DN	mm	50	65	80	100	150	200	250	300	350	400		
NPS	in	2	2 1/2	3	4	6	8	10	12	14	16		
L(RF)	mm	368	419	470	546	705	832	991	1130	1257	1384		
	in	14.5	16.5	18.5	21.5	27.75	32.75	39	44.5	49.5	54.5		
L1(BW)	mm	368	419	470	546	705	832	991	1130	1257	1384		
	in	14.5	16.5	18.5	21.5	27.75	32.75	39	44.5	49.5	54.5		
L2(RTJ)	mm	371	422	473	549	711	842	1000.5	1146	1276	1406		
	in	14.63	16.63	18.63	21.63	28	33.13	39.38	45.13	50.2	55.4		
H	mm	197	220	254	290	355	510	595	655	680	780		
	in	7.74	8.7	10	11.44	14	20	23.5	25.8	26.8	30.7		
Do(W)	mm	600	*350	*350	*600	*600	*800	*800	*800	*800	*800	*800	
	in	23.6	13.8	13.8	23.6	23.6	31.5	31.5	31.5	31.5	31.5	31.5	
RF(Kg)		55	80	97	162	290	390	745	935	1000	1305		
BW(Kg)		51	71	92.8	157.5	227	335	697	885	915	1200		

\*Worm Gear or Electric actuator operated.

## Top Entry Trunnion Mounted Ball Valve

Gate Valve, Globe Valve, Plug Valve, Check Valve, Butterfly Valve ,  
 Power Station Valve ,Oilfield Dedicated Valve Y-Strainer.

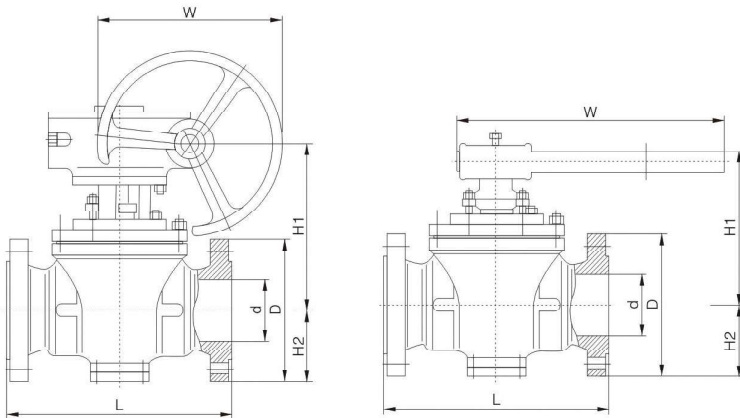

Design manufacture according  
 to API6D、ASME B16.34  
 Inspection and test to API 598  
 Flang to ASME B16.5、  
 DIN2543-2550、JB/T79.4  
 Material to NACE MRO175  
 Fire safe as per API 607、API 6FA

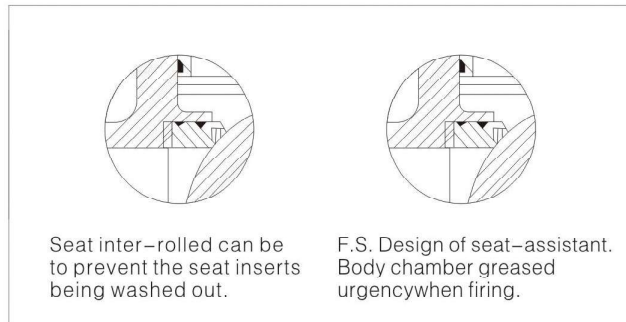
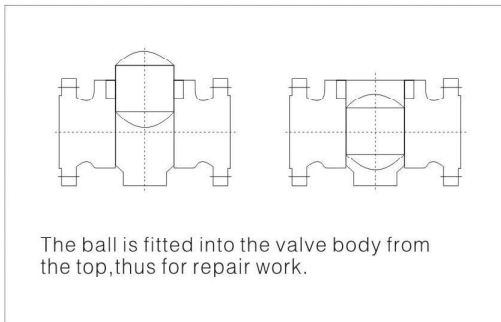

### Dimensions and mm and inches(Weights )

CLASS 150						
Size	G	L	H1	H2	W	Weight
in	in	in	in	in	in	kg
2	51	292	170	76	285	46
3	76	356	211	95	285	83
4	102	432	250	115	400	156
6	152	559	265	140	*400	256
8	203	660	355	172	*400	453
10	254	787	385	203	*600	622
12	305	838	400	242	*600	747
14	337	889	450	267	*600	959
16	387	991	510	299	*600	1220
18	438	1092	565	318	*600	1640
20	489	1194	620	349	*600	2118
24	591	1397	680	407	*700	2950

CLASS 300						
Size	G	L	H1	H2	W	Weight
in	in	in	in	in	in	kg
2	51	292	170	83	285	49
3	76	356	211	105	285	87
4	102	432	250	127	400	164
6	152	559	265	159	*400	272
8	203	660	355	191	*500	479
10	254	787	385	223	*600	657
12	305	838	400	261	*600	783
14	337	889	450	292	*600	1007
16	387	991	510	324	*600	1281
18	438	1092	565	356	*700	1722
20	489	1194	620	388	*700	2118
24	591	1397	680	457	*700	3100